

Sport Exhaust System (I-no. 176)

Revision: This bulletin replaces bulletin Group 2, #3/16, dated May 10, 2016.

Model Year: **As of 2017**

Concern: **Retrofitting**

Vehicle Type: **911 Carrera S (991)/911 Carrera 4S (991)/911 Targa 4S (991)**

Engine Type: **MDC.HA (MA2.02), 420 hp, 3.0 L "S" Engine**



Notes: The sport exhaust system is activated and deactivated using the switch console with the additional "Twin tailpipe" button. The sport exhaust system is also activated by pressing the "Sport" and "Sport Plus" buttons. The sport exhaust system can be switched off separately in these modes using the "Twin tailpipe" button.

The combined switch (switch console) and tailpipes must also be ordered. The switch console is modular and must be assembled in accordance with the new vehicle equipment.

Engine power and exhaust behavior of the vehicle are not affected.

Parts Info: **991.044.200.30** ⇒ Sport exhaust system, set

Also order.

991.044.200.24	1 x	⇒ Tailpipe, silver, set
991.613.955.50 DML¹	1 x	⇒ Combined switch (switch console), I-no. 652, Coupé
991.613.957.50 DML¹	1 x	⇒ Combined switch (switch console), I-no. 653, Coupé
991.613.959.50 DML¹	1 x	⇒ Combined switch (switch console), I-no. 651, Coupé
991.613.967.50 DML¹	1 x	⇒ Combined switch (switch console), I-no. 552, Cabriolet
991.613.963.50 DML¹	1 x	⇒ Combined switch (switch console), Targa

¹ Depending on vehicle equipment.

Parts List:

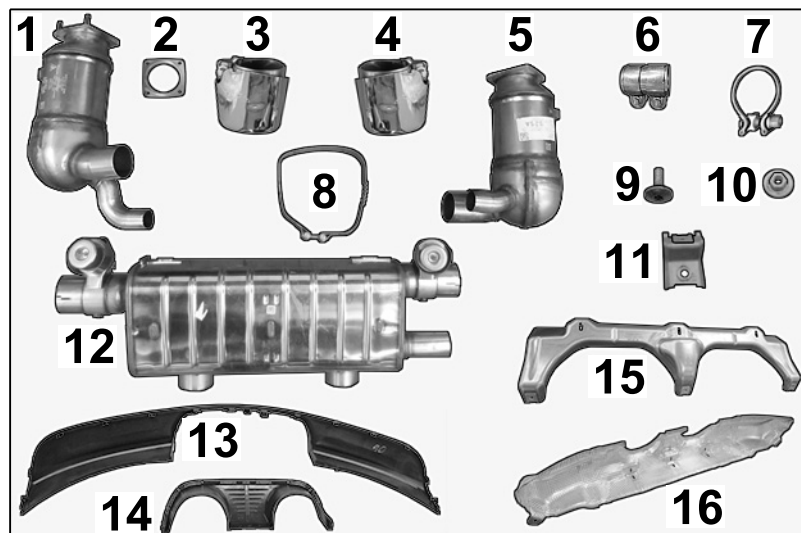

Figure 2

9P1.254.400.A	1 x	Left catalytic converter ⇒ <i>Figure 2-1-</i>
9P1.251.263	2 x	Seal ⇒ <i>Figure 2-2-</i>
9P1.251.187.B ²	1 x	Tailpipe, silver ⇒ <i>Figure 2-3-</i>
9P1.251.188.B ²	1 x	Tailpipe, silver ⇒ <i>Figure 2-4-</i>
9P1.254.450.A	1 x	Right catalytic converter ⇒ <i>Figure 2-5-</i>
9P1.253.145	2 x	Clamping sleeve ⇒ <i>Figure 2-6-</i>
997.111.230.80	2 x	Clamp ⇒ <i>Figure 2-7-</i>
9P1.251.751	2 x	Clamp on main muffler ⇒ <i>Figure 2-8-</i>
999.073.418.01	2 x	Tapping screw, ST 4.8 x 19-C ⇒ <i>Figure 2-9-</i>
999.076.091.01	2 x	Hexagon nut, M6 ⇒ <i>Figure 2-10-</i>
996.505.649.01	1 x	Bracket ⇒ <i>Figure 2-11-</i>
9P1.251.053.A	1 x	Main muffler ⇒ <i>Figure 2-12-</i>
991.505.811.040K1	1 x	Rear apron (black, grained) ⇒ <i>Figure 2-13-</i>
991.505.651.040K1	1 x	Tailpipe cover (black, grained) ⇒ <i>Figure 2-14-</i>
991.505.639.03	1 x	Rear support ⇒ <i>Figure 2-15-</i>

991.505.475.04	1 x	Heat shield ⇒ <i>Figure 2-16-</i>
999.507.309.02	4 x	Speed nut, ST 4.8 (not shown)
999.084.642.02	8 x	Hexagon nut, M8 (not shown)
991.505.837.02	1 x	Lower retaining strip, middle (not shown)
991.505.837.03	2 x	Lower retaining strip, outer (not shown)
999.190.191.30	3 x	Blind rivet, A3.2 x 17 (not shown)
9A7.007.483.00 ³	4 x	Torx screw (for securing seat), (not shown)
9P3.974.280 ³	1 x	Wire harness for sports exhaust system (not shown)
999.650.531.00 ³	1 x	Cable ring eyelet (not shown)
999.650.566.22 ³	1 x	Socket contact (not shown)
991.044.200.15 ³	1 x	Cable casing (not shown)
999.073.227.09	1 x	Tapping screw, ST 4.8 x 19 (not shown)
N 020.904.4 ³	15 x	Tie-wrap (not shown)
999.073.236.0A	8 x	Countersunk screw, M6 x 10 (for securing heat shield for turbocharger)

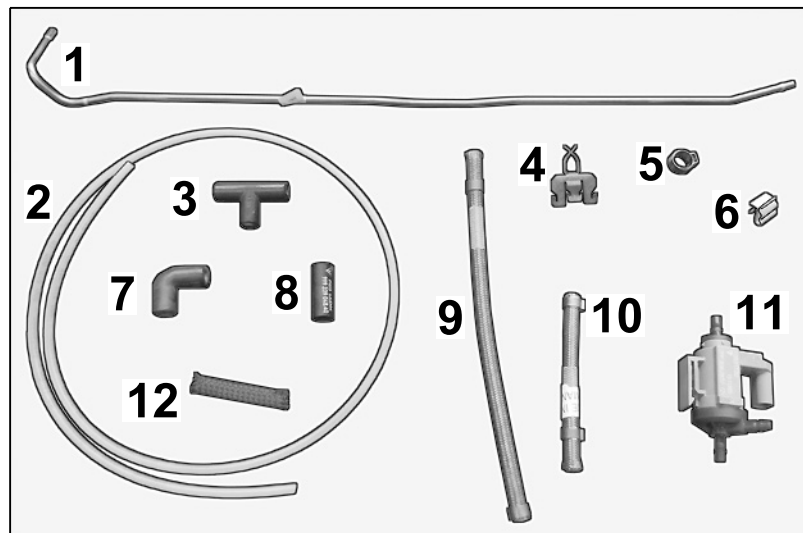

Figure 3

Parts included for vacuum supply system

9P1.251.838.A	1 x	Vacuum line, metal ⇒ <i>Figure 3-1-</i>
900.918.005.40	1 x	Plastic tube (5 x 1 x 1,000 mm) ⇒ <i>Figure 3-2-</i>
06E.133.794	3 x	T-piece ⇒ <i>Figure 3-3-</i>
999.651.363.01	1 x	Cable holder ⇒ <i>Figure 2-4-</i>
999.512.707.00	4 x	One-ear hose clamp, 9.6-11.3 ⇒ <i>Figure 3-5-</i>
999.651.401.01 ³	4 x	Clip (for securing vacuum line, metal) ⇒ <i>Figure 3-6-</i>
9A1.110.666.00	2 x	Molded hose ⇒ <i>Figure 3-7-</i>

999.239.048.40	1 x	Connecting hose (4.5 x 2.5 x 28 mm) ⇒ <i>Figure 3-8-</i>
991.111.504.00	1 x	190-mm steel flexi-pipe ⇒ <i>Figure 3-9-</i>
991.111.502.00	1 x	93-mm steel flexi-pipe ⇒ <i>Figure 3-10-</i>
7PP.906.283.F ³	1 x	Change-over valve ⇒ <i>Figure 3-11-</i>
999.181.518.50	1 x	Protective tube, L = 50 mm ⇒ <i>Figure 3-12-</i>

2 Contained in set 991.044.200.24.

3 Not required for installing the sport exhaust system on the S model.

Notes:

Identifying features when installed:

In addition to the Porsche logo, a part number is shown on the main muffler, catalytic converters and tailpipes.

Tools:

9900 - PIWIS Tester 3

WE1223 - Transmission and unit jack Junior Jack 2.0

Work Procedure: 1 Preparatory work:

1.1 Move convertible top to service position.

1.1.1 Cabriolet: ⇒ *Workshop Manual '6101IN Convertible-top service position (Cabriolet)'*

1.1.2 Targa: ⇒ *Workshop Manual '6101IN05 Convertible-top service position'*



WARNING

Moving components

- **Danger of limbs being trapped or severed**

⇒ **Do not reach into the danger area.**

⇒ **Secure the system to prevent it from being activated accidentally.**

⇒ **Keep third parties away from the danger area.**

1.2 Extend the rear spoiler manually using the rocker switch in the passenger compartment.

2 Remove the following components in the rear area.

2.1 Remove engine-compartment blower. ⇒ *Workshop Manual '198119 Removing and installing engine-compartment blower'*

2.2 Remove air guide. ⇒ *Workshop Manual '243619 Removing and installing air guide'*

2.3 Remove tail lights. ⇒ *Workshop Manual '943119 Removing and installing tail light'*

2.4 Remove rear apron. ⇒ *Workshop Manual '635519 Removing and installing rear apron'*

- 2.5 Remove bumper together with heat shield. ⇒ *Workshop Manual '635019 Removing and installing rear bumper'*
- 2.6 Remove rear spoiler. ⇒ *Workshop Manual '66581905 Removing and installing rear spoiler'*
- 2.7 Remove air guide on charge-air cooler ⇒ *Figure 4-1, 2.* ⇒ *Workshop Manual '211019 Removing and installing air guide for charge-air cooling'*

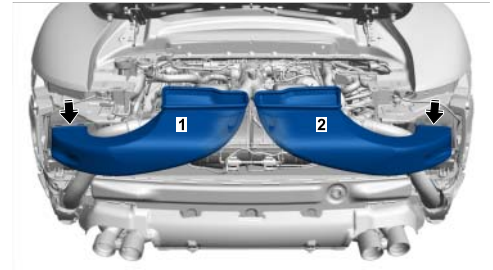

Figure 4

- 2.8 Remove pressure pipe ⇒ *Figure 5-1-.* ⇒ *Workshop Manual '214119 Removing and installing pressure pipe'*

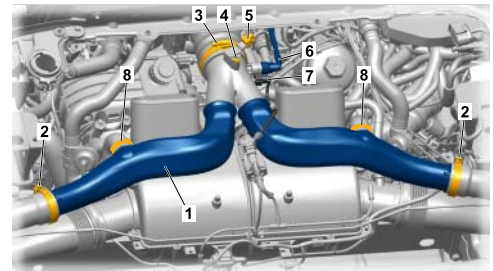

Figure 5

- 2.9 Remove air cleaner housing ⇒ *Figure 6-1-.* ⇒ *Workshop Manual '242519 Removing and installing air cleaner housing'*

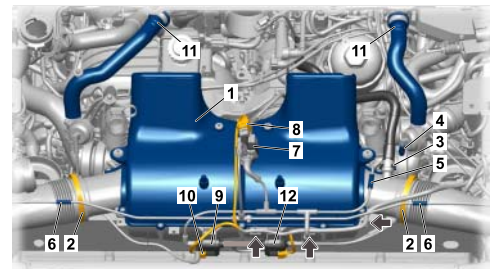

Figure 6

CAUTION

Hot components

- Risk of burns
- ⇒ Let hot components cool down.
- ⇒ Wear personal protective gear.

- 3 Remove exhaust system.

- 3.1 Remove heat shield for turbocharger at the left ⇒ *Figure 7-2-* and right.

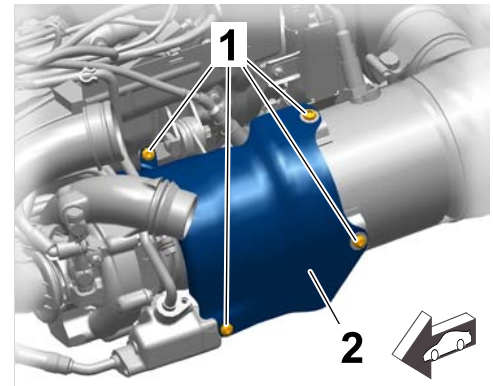

Figure 7

WARNING

Danger of objects or loads falling down

- Risk of squashing or crushing
- ⇒ Secure components to prevent them from falling down.



Information

The exhaust system must only be removed with the help of another person.

- 3.2 Remove exhaust system. ⇒ *Workshop Manual '260119 Removing and installing exhaust system'*
- 4 Install vacuum line.
- 4.1 Remove standard vacuum line from the clips ⇒ *Figure 8-2-* on the engine carrier ⇒ *Figure 8-1-*.
- 4.2 Assemble vacuum line.
- 4.2.1 Cut off 3 sections (length: 25 mm, 70 mm, 350 mm) of plastic tube (900.918.005.40).

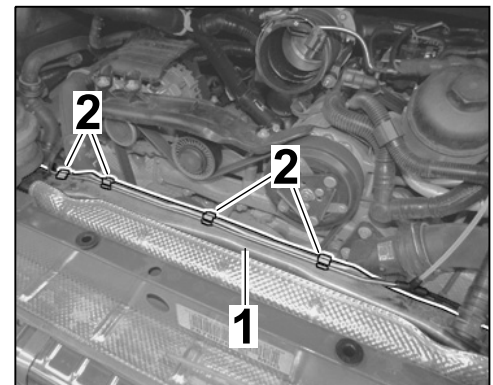

Figure 8

4.2.2 Connect components together as shown in Figure 9.

- 1 - 190-mm steel flexi-pipe
- 2 - One-ear hose clamp
- 3 - Plastic tube (25 mm)
- 4 - Moulded hose
- 5 - Plastic tube (70 mm)
- 6 - Protective tube (50 mm)
- 7 - T-piece
- 8 - Plastic tube (350 mm)
- 9 - Moulded hose

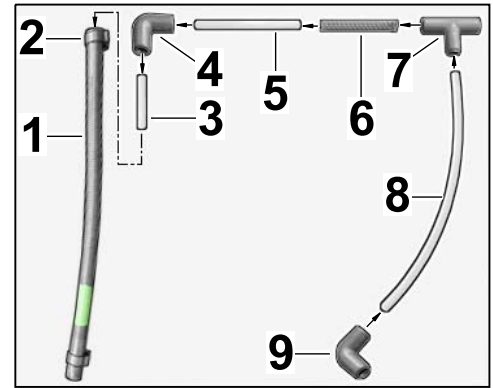

Figure 9

Press one-ear hose clamp ⇒ Figure 9-2- together.

4.2.3 Insert metal vacuum line (9P1.251.838.A) ⇒ Figure 10-3- as far as the marking (white) ⇒ Figure 10-**arrow a**- into the T-piece ⇒ Figure 10-4-.

Insert metal vacuum line as far as the marking (white) ⇒ Figure 10-**arrow a**- into the 93-mm steel flexi-pipe ⇒ Figure 10-1-.

Press one-ear hose clamp ⇒ Figure 10-2- together.

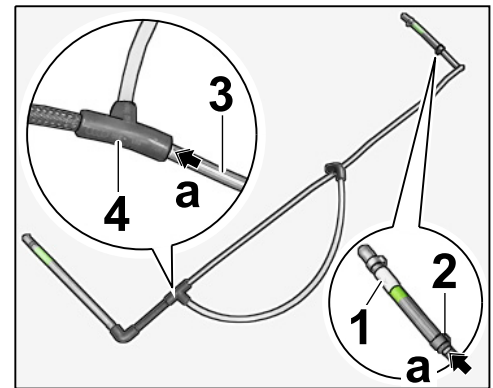

Figure 10

4.3 Fit assembled vacuum line ⇒ Figure 11-1- into the standard clips ⇒ Figure 11-2- on the engine carrier.

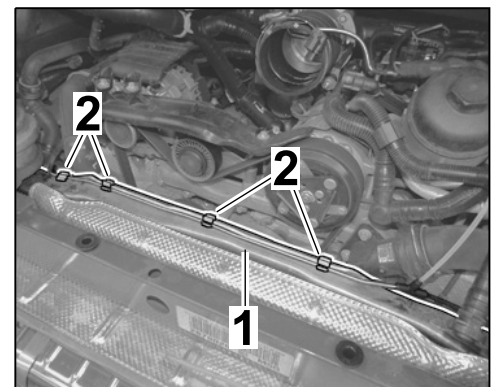

Figure 11

- 4.4 Clip steel flexi-pipe ⇒ *Figure 12-2-* into cable holder ⇒ *Figure 12-1-*.
- 5 Install sports exhaust system.

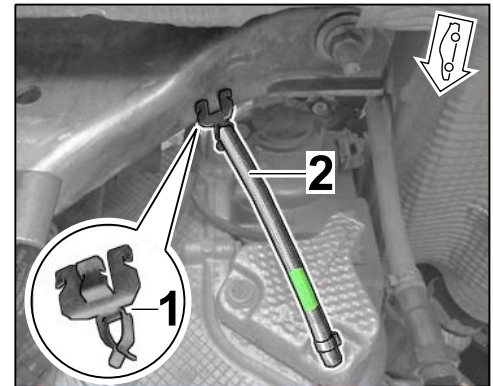

Figure 12

- 5.1 Fit right catalytic converter ⇒ *Figure 13-1-* with a new seal on the turbocharger ⇒ *Figure 13-3-* and secure with a new hexagon nut ⇒ *Figure 13-2-* to prevent it from falling down.

**Information**

The oxygen sensors can only be screwed by 4 – 5 turns without disconnecting the electric plug connections.

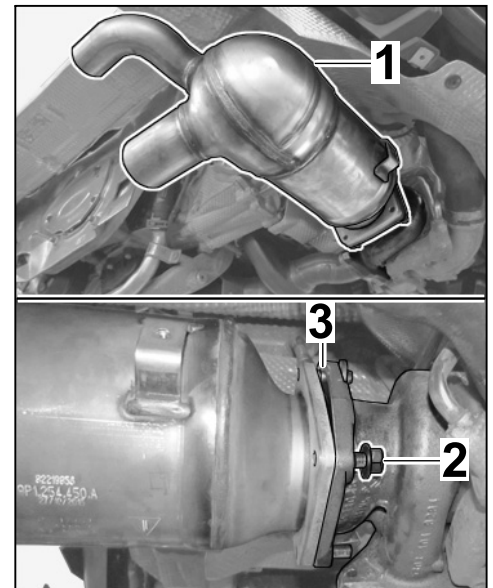

Figure 13

**Information**

- When re-installing oxygen sensors, only grease the thread with lubricant.

- New oxygen sensors have already been greased and the thread is fitted with a protection cap.

5.2 Install oxygen sensors upstream of catalytic converter ⇒ *Figure 14-1-* and downstream of catalytic converter ⇒ *Figure 14-2-* on the right catalytic converter.

Tightening torque 50 Nm (37 ftlb.) +/-8 Nm (+/-6 ftlb.)

5.3 Fit left catalytic converter with a new seal on the turbocharger and secure with a new hexagon nut to prevent it from falling down.



Information

The oxygen sensors can only be screwed by 4 – 5 turns without disconnecting the electric plug connections.

5.4 Install oxygen sensor upstream and downstream of catalytic converter on the left catalytic converter.

Tightening torque 50 Nm (37 ftlb.) +/-8 Nm (+/-6 ftlb.)

5.5 Fit clamping sleeve at the left ⇒ *Figure 15-1-* and right on the catalytic converters.

Fit clamps ⇒ *Figure 15-2-* on the main silencer.

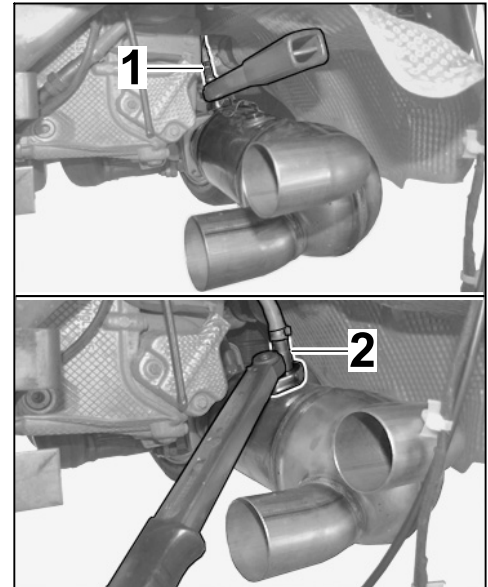

Figure 14

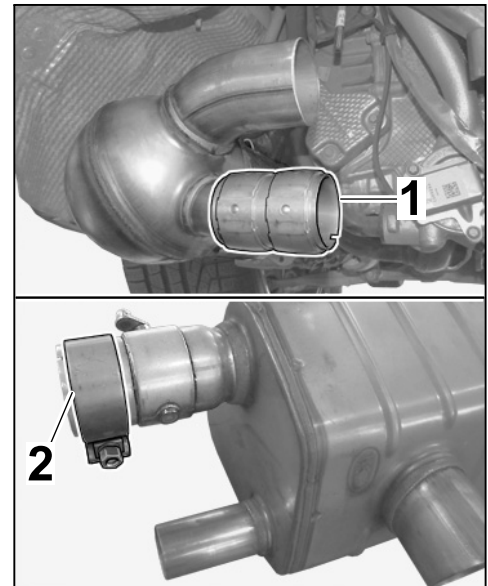
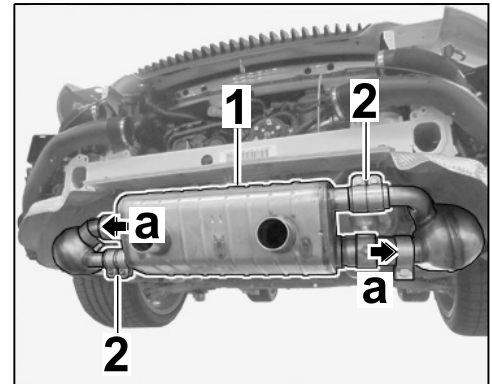

Figure 15

**Information**

- Apply a light coating of high-temperature grease (e.g. Optimoly HT, Part No. 000.043.004.00) on the clamp or pipe adapter before installation.

- 5.6 Guide main silencer ⇒ *Figure 16-1-* into the catalytic converter at the left and right with the help of another person ⇒ *Figure 16-a-*.
Slide clamping sleeves ⇒ *Figure 16-2-* over the pipe adapters.

*Figure 16*

- 5.7 Fit restraining straps ⇒ *Figure 17-1-*.

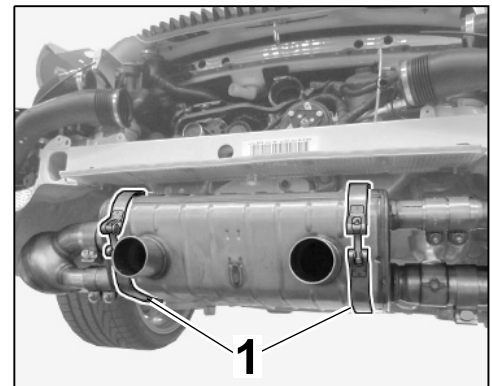
*Figure 17*

- 5.8 Slide vacuum line at the left and right ⇒ *Figure 18-1-* onto the exhaust flap control box and press one-ear hose clamp ⇒ *Figure 18-2-* together.

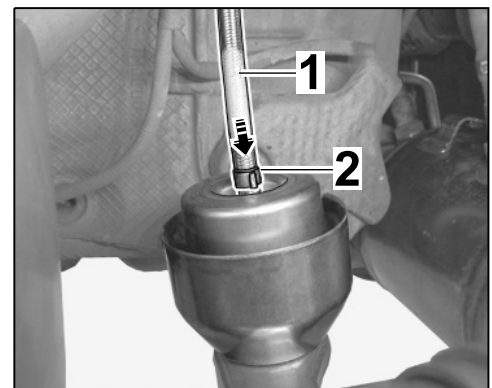
*Figure 18*

- 5.9 Position main muffler with lock ⇒ *Figure 19*
 -1- on the main muffler holder ⇒ *Figure 19*
 -2- (⇒ *Figure 20*-arrow-).

Tighten restraining straps.

Tightening torque 15 Nm (11 ftlb.) +/-10 %

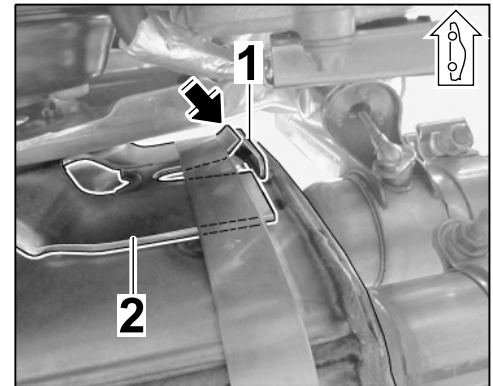

Figure 19

- 5.10 Fit and tighten the remaining hexagon nuts ⇒ *Figure 20*-1- securing the catalytic converters to the turbocharger.

Tightening torque 25 Nm (19 ftlb.) +/-10 %

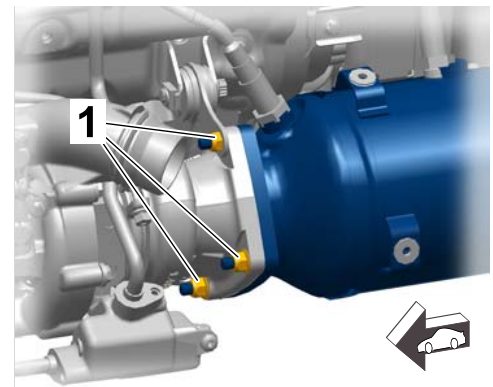

Figure 20

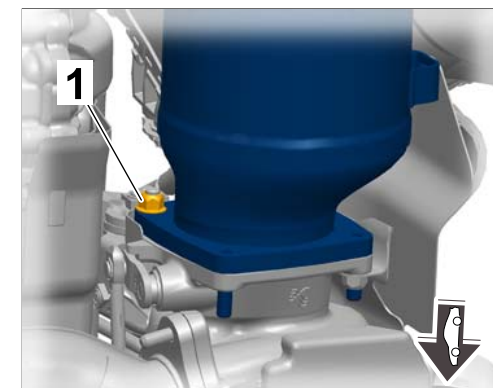
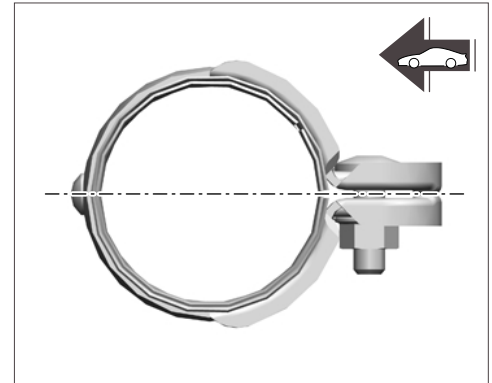

Figure 21

**Information**

It is important to ensure that the clamps and pipe joiners are tightened in horizontal position.



Clamps must be horizontal when tightened

5.11 Tighten clamping sleeves \Rightarrow *Figure 22-4-* and clamps \Rightarrow *Figure 22-1-*.

5.11.1 Tighten clamping sleeves.
Tightening torque 30 Nm (22 ftlb.)

5.11.2 Tighten clamps.
Tightening torque 55 Nm (41 ftlb.) +/-10%

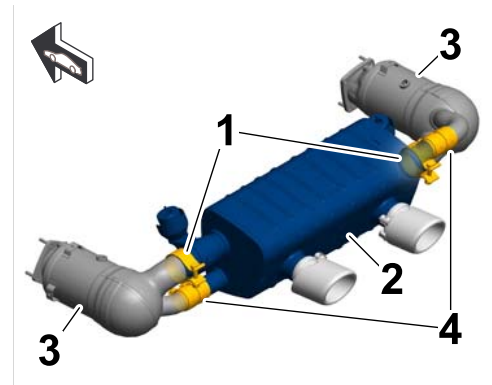

Figure 22

5.12 Install heat shield for turbocharger at the left \Rightarrow *Figure 23-2-* and right.

6 Convert heat shield on bumper.

6.1 Remove standard heat shield from rear bumper.

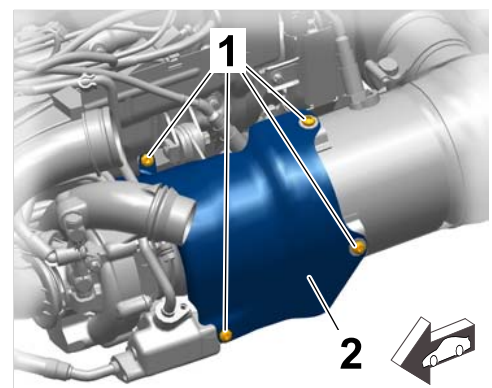

Figure 23

- 6.1.1 Unscrew tapping screw ⇒ *Figure 24-1-* and remove bracket ⇒ *Figure 24-2-*.

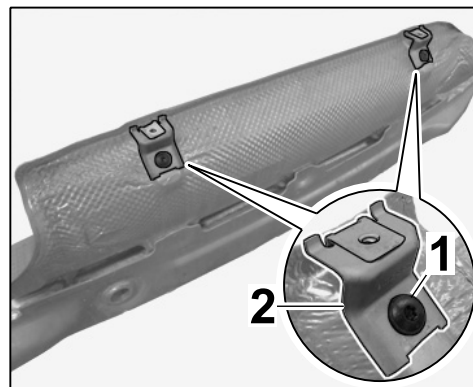

Figure 24

- 6.1.2 Unscrew hexagon nuts ⇒ *Figure 25-1-* and remove rear supports ⇒ *Figure 25-2-*.

- 6.1.3 Disconnect heat shield and rear bumper.

- 6.2 Assemble new heat shield and bumper.

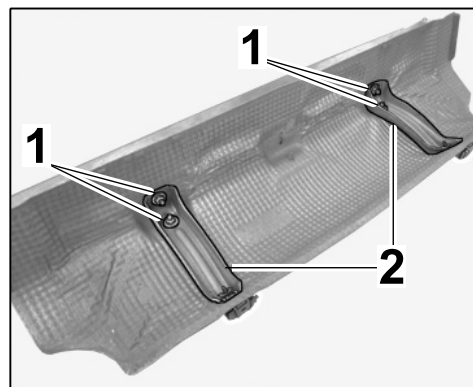

Figure 25

- 6.2.1 Position rear support ⇒ *Figure 26-1-* on the heat shield. Screw on and tighten hexagon nuts ⇒ *Figure 26-2-*.

Tightening torque 9.7 Nm (7.5 ftlb.)

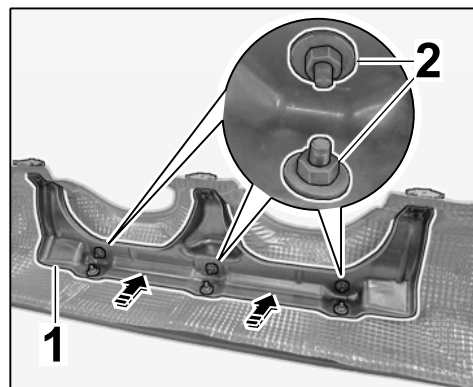

Figure 26

- 6.2.2 Position fastening bracket ⇒ *Figure 27-1-* and screw in and tighten tapping screw ⇒ *Figure 27-2-*.
Tightening torque 2.8 Nm (2 ftlb.)

7 Convert rear apron.

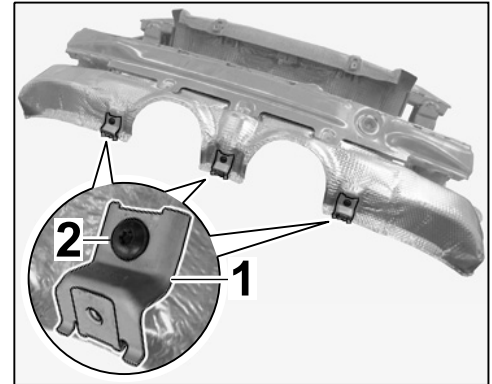

Figure 27

- 7.1 Remove rear skirt. ⇒ *Workshop Manual '636819 Removing and installing rear skirt'*
- 7.2 Make cut-out for new rear skirt.
 - 7.2.1 Mark rear apron.



Figure 28

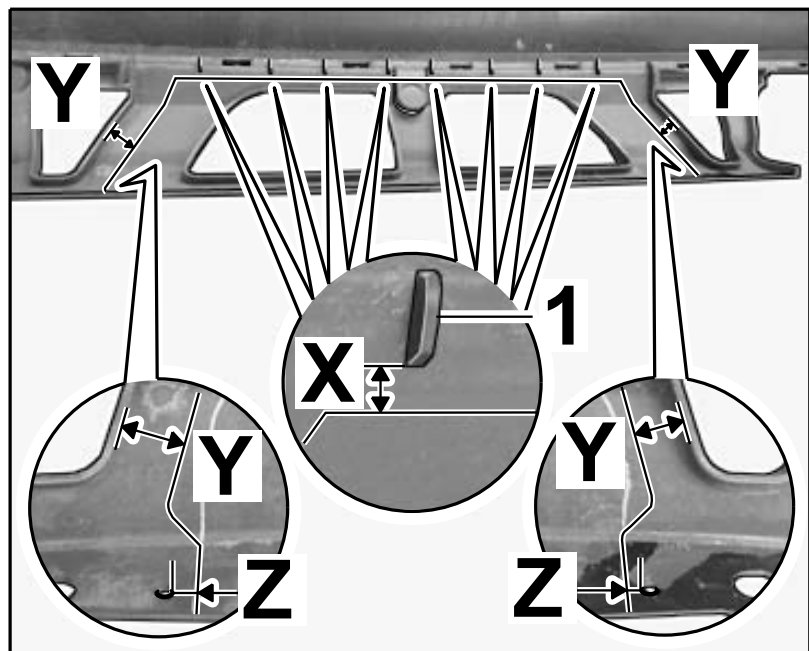

Figure 29

- 1 - Bar
- X - Distance from bar: 5 mm
- Y - Dimension = 16 mm

Z – Distance from edge of hole: 5 mm

7.2.2 Saw along the marking using a body saw.

Re-work cut edges if necessary.

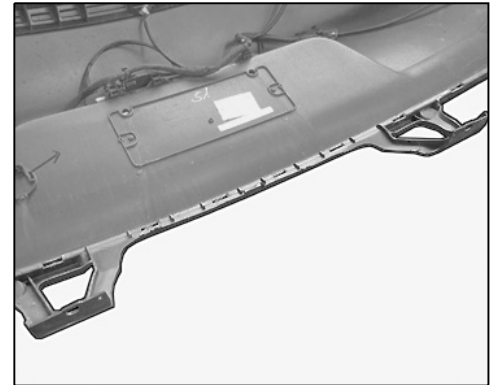

Figure 30

7.3 Clip tailpipe cover ⇒ *Figure 31 -1-* into the rear skirt ⇒ *Figure 31 -2-*.

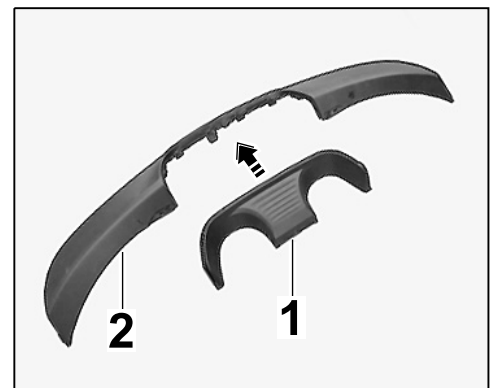

Figure 31

7.4 Clip rear skirt ⇒ *Figure 32 -1-* into the rear apron ⇒ *Figure 32 -2-*.
Screw in and tighten screws ⇒ *Figure 32 -3-*.

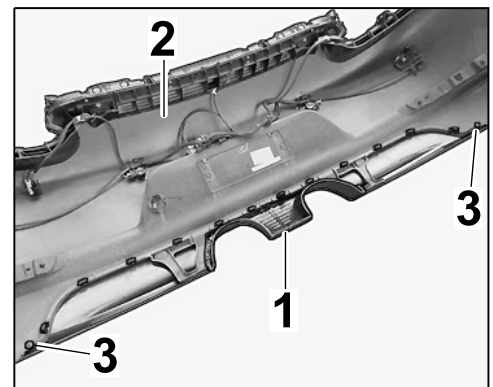

Figure 32

- 7.5 Secure center retaining strip ⇒ *Figure 33 -2-* and two retaining strips at the outside ⇒ *Figure 33-1-* to the rear apron using rivets.
- 8 Concluding work:
- 8.1 Install the air cleaner housing. ⇒ *Workshop Manual '242519 Removing and installing the air cleaner housing'*
- 8.2 Install pressure pipe. ⇒ *Workshop Manual '214119 Removing and installing pressure pipe'*
- 8.3 Install air guide for charge-air cooler ⇒ *Figure 34 -1, 2-*.
- 8.4 Install rear spoiler. ⇒ *Workshop Manual '66581905 Removing and installing rear spoiler'*
- 8.5 Install engine-compartment blower. ⇒ *Workshop Manual '198119 Removing and installing engine-compartment blower'*
- 8.6 Install bumper.
- 8.6.1 Unscrew screws ⇒ *Figure 35 -1-* on the heat shield.
- 8.6.2 Install bumper together with heat shield. ⇒ *Workshop Manual '635019 Removing and installing rear bumper'*

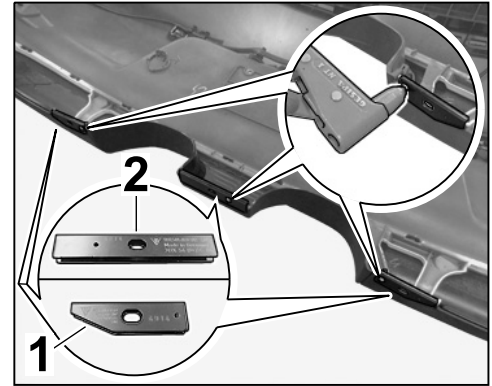

Figure 33

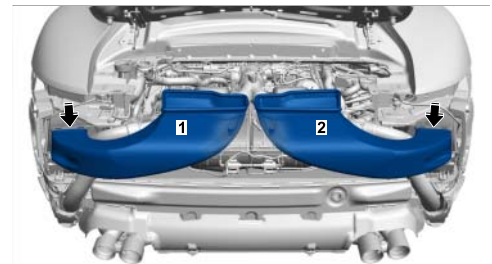

Figure 34

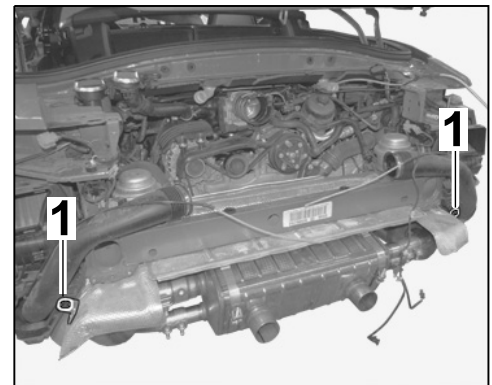

Figure 35

- 8.6.3 Tighten screws ⇒ *Figure 36 -1-* on the heat shield.

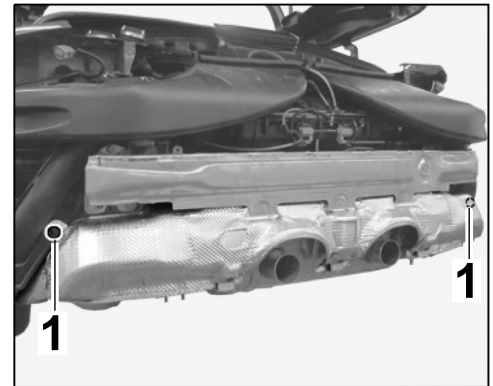

Figure 36

- 8.7 Install rear apron. ⇒ *Workshop Manual '635519 Removing and installing rear apron'*
Secure rear apron in the center using a new tapping screw (999.073.227.09 ⇒ *Figure 37-1-*).
- 8.8 Install bumper.

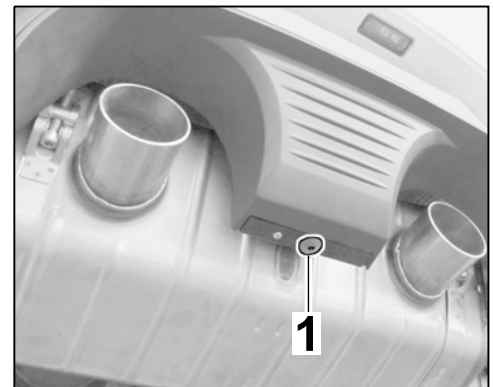

Figure 37

- 8.8.1 Unscrew screws ⇒ *Figure 38 -1-* on the heat shield.
- 8.8.2 Install bumper together with heat shield. ⇒ *Workshop Manual '635019 Removing and installing rear bumper'*

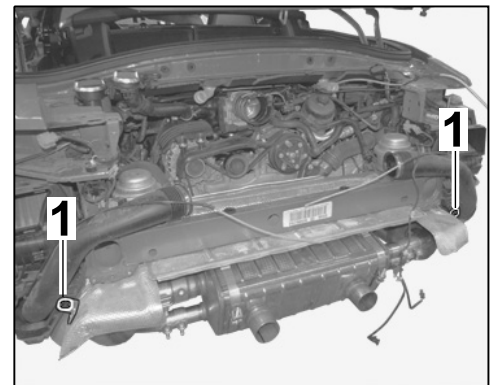

Figure 38

- 8.8.3 Tighten screws ⇒ *Figure 39-1* on the heat shield.
- 8.9 Install rear apron. ⇒ *Workshop Manual '635519 Removing and installing rear apron'*
- 8.10 Install tailpipes. ⇒ *Workshop Manual '263519 Removing and installing tailpipe cover'*
- 8.11 Install tail lights. ⇒ *Workshop Manual '943119 Removing and installing tail light'*

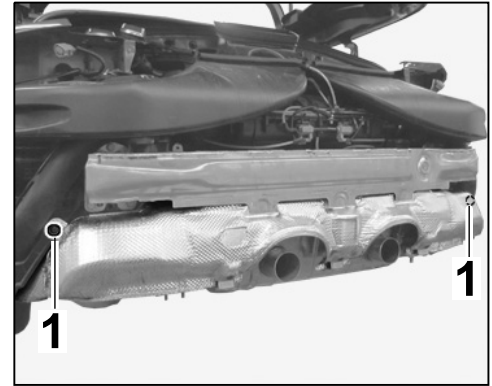

Figure 39

WARNING

Moving components

- **Danger of limbs being trapped or severed**
- ⇒ **Do not reach into the danger area.**
- ⇒ **Secure the system to prevent it from being activated accidentally.**
- ⇒ **Keep third parties away from the danger area.**

- 8.12 Retract the rear spoiler manually using the rocker switch in the passenger compartment.
- 8.13 Convert switch console.
- 8.13.1 Remove switch console. ⇒ *Workshop Manual '962719 Removing and installing switch console'*



Information

The switch console consists of a total of 16 buttons, 10 light guides and 10 trims. Each half can be used for the left or right row of the main body.

- 8.13.2 Assemble new switch console in accordance with the new vehicle equipment.

Fit light guide at the correct side ⇒
Figure 40-1- in the main body ⇒
Figure 40-arrow-.

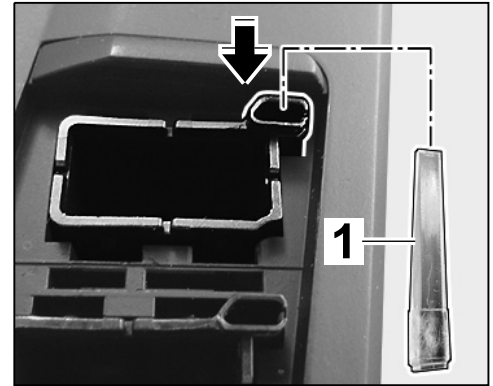

Figure 40

Fit trim ⇒ Figure 41-1- underneath
the button in the main body ⇒
Figure 41-arrows-.

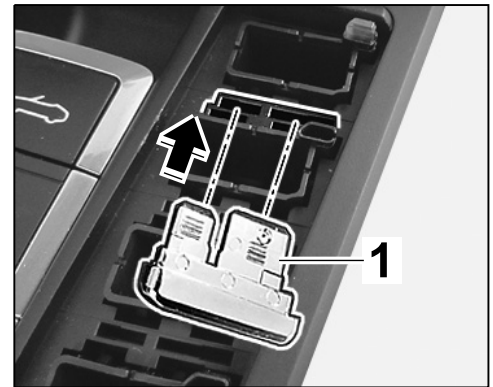

Figure 41

Position button ⇒ Figure 42-1- and
clip it into the main body ⇒ Figure
42-arrow-.

8.13.3 Install switch console. ⇒ *Workshop
Manual '962719 Removing and
installing switch console'*

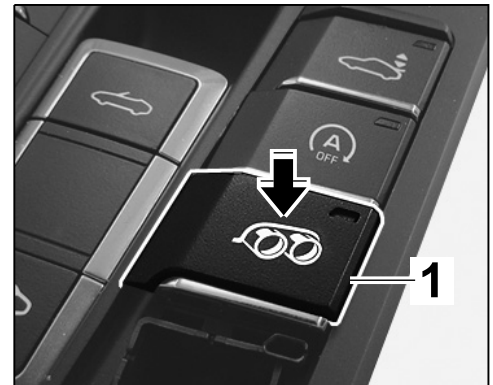

Figure 42

NOTICE

Voltage drop

- Risk of irreparable damage to control unit
- Risk of damage to control unit

- **Fault entries in the control unit**
 - **Coding in the control unit is aborted**
 - **Malfunctions in control unit, even during programming**
- ⇒ **Switch off the ignition and remove the ignition key before disconnecting the control unit.**
- ⇒ **Ensure that the power supply is not interrupted during programming.**
- ⇒ **Connect a battery charger with a current rating of at least Nominal value 70 A to the vehicle battery.**



Information

The **9900 - PIWIS Tester 3** instructions take precedence since the description may be different with later Tester releases.

The procedure described here has been structured in general terms; different text or additions may appear on the **9900 - PIWIS Tester 3**.

9 Code sports exhaust system.

9.1 **9900 - PIWIS Tester 3** must be connected before switching on the ignition.

9.2 Select the required vehicle type. PIWIS Tester Diagnostics starts.



Information

The sport exhaust system button can only be coded on the right-hand side of the switch console.

9.3 Code keypad assignment. ⇒ *Workshop Manual '962755 Replacing switch console'*

9.4 Maintenance of vehicle data

9.4.1 **Additional menu** must now be selected by pressing •F7" .

9.4.2 Select the **Maintenance of vehicle data** function. Press •F12" until **M numbers** appears in the Value group column.

9.4.3 Select **176 - Sports exhaust system** in the Coding value column. When you touch the Installed cell, a tick appears.

9.4.4 Save the values by pressing •F8" . Wait until the message **Modified values have been buffered** appears.

9.4.5 Press •F12" until •F8" can be activated.

9.4.6 Press •F8" to write values. Wait until the message **Generation of vehicle data is complete** appears.

9.4.7 Press •F12" to switch to Report management. Open the log by pressing •F10" and check that vehicle equipment **176 Sports exhaust system** is displayed.

- 9.5 Adapt coding.
 - 9.5.1 Press **•F11** to return to the list of control units.
Select all control units.
 - 9.5.2 Switch to the **Codings/adaptations** menu.
Select **Automatic coding**. Press **•F12** to continue.
Wait until the message **Coding has been completed successfully** appears.
Press **•F12** to continue.
- 9.6 Read out the fault memories of all systems, work through any existing faults and erase the fault memories. ⇒ *Workshop Manual '033500 Fault memory for on-board diagnosis'*
- 9.7 Switch off ignition and disconnect **9900 - PIWIS Tester 3**.
- 9.8 Carry out "Sport exhaust system" function test.

The exhaust flaps open when you press the "Twin tailpipe" button. The noise of the exhaust motor can be heard.
- 9.9 Disconnect battery charger. ⇒ *Workshop Manual '2X00IN Battery trickle charging'*

26013100: Installing sport exhaust system

Labor time: **487 TU**

Includes:

Removing and installing exhaust system, rear skirt and switch console; replacing catalytic converters and main muffler; coding sport exhaust system and strip for switches.

Important Notice: Technical Bulletins issued by Porsche Cars North America, Inc. are intended only for use by professional automotive technicians who have attended Porsche service training courses. They are written to inform those technicians of conditions that may occur on some Porsche vehicles, or to provide information that could assist in the proper servicing of a vehicle. Porsche special tools may be necessary in order to perform certain operations identified in these bulletins. Use of tools and procedures other than those Porsche recommends in these bulletins may be detrimental to the safe operation of your vehicle, and may endanger the people working on it. Properly trained Porsche technicians have the equipment, tools, safety instructions, and know-how to do the job properly and safely. If a particular condition is described, do not assume that the bulletin applies to your vehicle, or that your vehicle will have that condition. See your authorized Porsche Dealer for the latest information about whether a particular technical bulletin applies to your vehicle. Part numbers listed in these bulletins are for reference only. Always check with your authorized Porsche dealer to verify the current and correct part numbers. The work procedures updated electronically in the Porsche PIWIS diagnostic and testing device take precedence and, in the event of a discrepancy, the work procedures in the PIWIS Tester are the ones that must be followed.

© Porsche Cars North America, Inc.

Dealership	Service Manager	Shop Foreman	Service Technician
Distribution	Asst. Manager	Warranty Admin.	Service Technician
Routing			

Dr. Ing. h.c. F. Porsche AG is the owner of numerous trademarks, both registered and unregistered, including without limitation the Porsche Crest®, Porsche®, Boxster®, Carrera®, Cayenne®, Cayman®, Macan®, Panamera®, Speedster®, Spyder®, 918 Spyder®, Tiptronic®, VarioCam®, PCM®, PDK®, 911®, RS®, 4S®, FOUR, UNCOMPROMISED®, and the model numbers and the distinctive shapes of the Porsche automobiles such as, the federally registered 911 and Boxster automobiles. The third party trademarks contained herein are the properties of their respective owners. Porsche Cars North America, Inc. believes the specifications to be correct at the time of printing. Specifications, performance standards, standard equipment, options, and other elements shown are subject to change without notice. Some options may be unavailable when a car is built. Some vehicles may be shown with non-U.S. equipment. The information contained herein is for internal authorized Porsche dealer use only and cannot be copied or distributed. Porsche recommends seat belt usage and observance of traffic laws at all times.

Printed in the USA